

## VERSIONE DOPPIA

DOUBLE VERSION

DOPPELTE VERSION

VERSIÓN DOBLE

VERSION DOUBLE

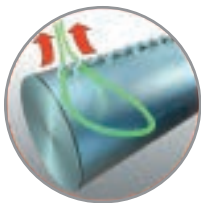
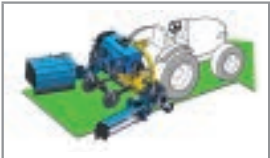

Sistema rapido per il cambio dei fili  
 Quick and tool-free wire replacement system  
 Schnelles und werkzeugloses Drahtwechselsystem  
 Sistema cambio de hilo rápido  
 Système rapide de remplacement du fil

MOD							
mod.	cod.	HP	rpm/min	type	cm	cm	kg
<b>CST+DMI doppia</b>	1002955	50 - 100	540	T-50 / T-60	75	220×175×110	620
<b>CST+DMI doppia compatta</b>	1003033	50 - 100	540	T-50 / T-60	75	168×165×110	510

Di serie	Standard equipment	Serienmässig	Estándar	De série
<ul style="list-style-type: none"> <li>Attacco a 3 punti Cat. I-II</li> <li>Impianto oleodinamico completo di serbatoio, sistema filtrante e scambiatore di calore</li> <li>Joystick multifunzione</li> <li>Spostamento laterale idraulico apertura/chiusura</li> <li>Regolazioni posizione rotore regolabili idraulicamente</li> <li>Regolazione dei giri direttamente dal trattore</li> <li>Sistema rapido per il cambio dei fili</li> <li>Sistema antishock regolabile per l'attenuazione dell'urto</li> <li>Ruote di appoggio con cresta regolabili in altezza</li> <li>Protezioni antinfortunistiche a normative CE</li> </ul>	<ul style="list-style-type: none"> <li>3-point linkage cat. I-II</li> <li>Hydraulic system complete with tank, filter system and heat exchanger</li> <li>Multifunction Joystick</li> <li>Hydraulic side shift opening/closing</li> <li>Hydraulically adjustable rotor positions</li> <li>RPM adjustment directly from the tractor</li> <li>Quick and tool-free wire replacement system</li> <li>Adjustable anti-shock system for shock absorption</li> <li>Height-adjustable crest wheels</li> <li>Protective equipment as per EC safety rules</li> </ul>	<ul style="list-style-type: none"> <li>3-Punkt-Anbau Kat. I-II</li> <li>Hydraulisches System komplett mit Tank, Filtersystem und Wärmetauscher</li> <li>Multifunktions-Joystick</li> <li>Hydraulische Seitenverschiebung öffnen/schließen</li> <li>Hydraulisch einstellbare Rotorpositionen</li> <li>Drehzahleinstellung direkt vom Traktor aus</li> <li>Schnelles und werkzeugloses Drahtwechselsystem</li> <li>Einstellbares Anfahrssicherungssystem zur Stoßdämpfung</li> <li>Höhenverstellbare Räder mit Führung</li> <li>Unfallschutz nach EU-Vorschriften</li> </ul>	<ul style="list-style-type: none"> <li>Enganche a 3 punto Cat. I-II</li> <li>Kit de centralita hidráulica completa de depósito, sistema filtrante e intercambiador de calor</li> <li>Joystick multifunción</li> <li>Desplazamiento lateral hidráulico apertura/cierre</li> <li>Regulación de la posición del rotor hidráulicamente</li> <li>Regulación del número de vueltas desde el tractor</li> <li>Sistema cambio de hilo rápido</li> <li>Sistema anti impacto, regulable para amortiguar golpe</li> <li>Rueda de apoyo con regulación en altura</li> <li>Protecciones de seguridad de acuerdo con la norma CE</li> </ul>	<ul style="list-style-type: none"> <li>Attelage 3 points Cat. I-II</li> <li>Système hydraulique complet avec réservoir, système de filtrage et échangeur de chaleur</li> <li>Joystick multifonction</li> <li>Déplacement latéral hydraulique ouverture/fermeture</li> <li>Réglages hydraulique de la position du rotor</li> <li>Réglage de la vitesse gére directement de le tracteur</li> <li>Système rapide de remplacement du fil</li> <li>Système antichoc réglable pour atténuer l'impact</li> <li>Roues de support avec guide réglables en hauteur</li> <li>Protections contre les accidents aux normes CE</li> </ul>

cod.	A richiesta	On request	Auf Anfrage	Opcionales	Sur demande
5130005	Cardano T-50	PTO shaft T-50	Gelenkwelle T-50	Cardán T-50	Cardan T-50
5130009	Cardano T-60	PTO shaft T-60	Gelenkwelle T-60	Cardán T-60	Cardan T-60
5411041	Ruota in ferro senza cresta	Smooth iron wheel	Glatte Eisenräder	Rueda de hierro lisa	Roue en fer lisse

**CST+DMI DOPPIA**  
**CST+DMI DOPPIA**  
**CST+DMI DOPPIA**  
**CST+DMI DOPPIA**

**INDIPENDENT CASTLE with INTER-ROW MECHANICAL WEEDER**  
**MECHANISHE UNKRAUTMÄHBÜRSTE**  
**DESBROZADORA INTERLÍNEAS MECÁNICA**  
**MACHINE Á ÉBOURGEONNER AVEC PALPEUR MÉCANIQUE**



ORIGINAL MADE IN ITALY | zanon.it

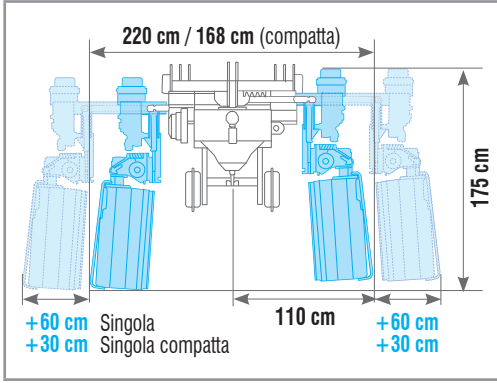
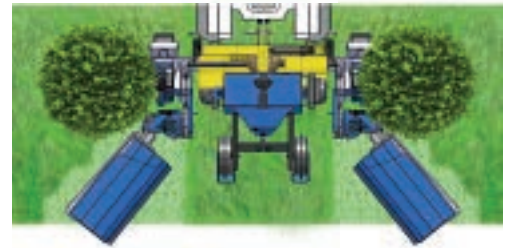
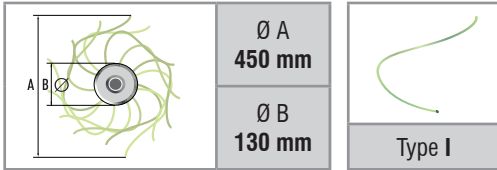

Sistema antishock regolabile per l'attenuazione dell'urto  
 Adjustable anti-shock system for shock absorption  
 Einstellbares Anfahrsicherung-System zur Stoßdämpfung  
 Sistema anti impacto regulable para amortiguar golpe  
 Système antichoc réglable pour atténuer l'impact



Joystick multifunzione con base magnetica  
 Multifunction Joystick with magnetic base  
 Multifunktions-Joystick bedienung mit magnet  
 Joystick multifunción con base magnética  
 Joystick multifonction avec base magnétique



Scambiatore di calore  
 Heat exchanger  
 Wärmetauscher  
 Intercambiador de calor  
 Échangeur de chaleur

cod.	Ricambi	Spare parts	Ersatzteile	Recambios	Pièces de rechange
5450043	Bobina filo 630 mt Ø 4 mm	Wire 630 mt Ø 4 mm	Garnrolle 630 mt Ø 4 mm	Hilo 630 mt Ø 4 mm	Bobine de fil 630 mt Ø 4 mm